

V42

CANADA
Yorkville Sound
550 Granite Court
Pickering, Ontario
L1W-3Y8 CANADA

Voice: (905) 837-8481
Fax: (905) 837-8746

U.S.A.
Yorkville Sound Inc.
4625 Witmer Industrial Estate
Niagara Falls, New York
14305 USA

Voice: (716) 297-2920
Fax: (716) 297-3689

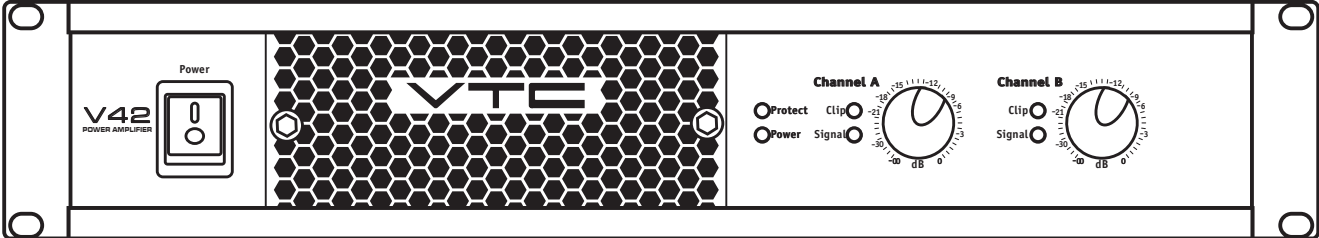

Service Manual

IMPORTANT SAFETY INSTRUCTIONS



This lightning flash with arrowhead symbol, within an equilateral triangle, is intended to alert the user to the presence of uninsulated "dangerous voltage" within the product's enclosure that may be of sufficient magnitude to constitute a risk of electric shock to persons.

Ce symbole d'éclair avec tête de flèche dans un triangle équilatéral est prévu pour alerter l'utilisateur de la présence d'un « voltage dangereux » non-isolé à proximité de l'enceinte du produit qui pourrait être d'ampleur suffisante pour présenter un risque de choc électrique.



CAUTION AVIS

RISK OF ELECTRIC SHOCK
DO NOT OPEN

RISQUE DE CHOC ELECTRIQUE
NE PAS OUVRIR



The exclamation point within an equilateral triangle is intended to alert the user to the presence of important operating and maintenance (servicing) instructions in the literature accompanying the appliance.

Le point d'exclamation à l'intérieur d'un triangle équilatéral est prévu pour alerter l'utilisateur de la présence d'instructions importantes dans la littérature accompagnant l'appareil en ce qui concerne l'opération et la maintenance de cet appareil.



SZ125A

FOLLOW ALL INSTRUCTIONS

Instructions pertaining to a risk of fire,
electric shock, or injury to a person

CAUTION: TO REDUCE THE RISK OF ELECTRIC SHOCK, DO NOT REMOVE COVER (OR BACK).

NO USER SERVICEABLE PARTS INSIDE.

REFER SERVICING TO QUALIFIED SERVICE PERSONNEL.

SUIVEZ TOUTES LES INSTRUCTIONS

Instructions relatives au risque de feu,
choc électrique, ou blessures aux personnes

AVIS: AFIN DE REDUIRE LES RISQUE DE CHOC ELECTRIQUE, N'ENLEVEZ PAS LE COUVERT (OU LE PANNEAU ARRIERE) NE CONTIENT AUCUNE PIECE

REPARABLE PAR L'UTILISATEUR.

CONSULTEZ UN TECHNICIEN QUALIFIE POUR L'ENTRETIEN

Read Instructions: The Owner's Manual should be read and understood before operation of your unit. Please, save these instructions for future reference and heed all warnings.

Clean only with dry cloth.

Packaging: Keep the box and packaging materials, in case the unit needs to be returned for service.

Warning: To reduce the risk of fire or electric shock, do not expose this apparatus to rain or moisture. *Do not use this apparatus near water!*

Warning: When using electric products, basic precautions should always be followed, including the following:

Power Sources

Your unit should be connected to a power source only of the voltage specified in the owners manual or as marked on the unit. This unit has a polarized plug. Do not use with an extension cord or receptacle unless the plug can be fully inserted. Precautions should be taken so that the grounding scheme on the unit is not defeated. An apparatus with CLASS I construction shall be connected to a Mains socket outlet with a protective earthing ground. Where the MAINS plug or an appliance coupler is used as the disconnect device, the disconnect device shall remain readily operable.

Hazards

Do not place this product on an unstable cart, stand, tripod, bracket or table. The product may fall, causing serious personal injury and serious damage to the product. Use only with cart, stand, tripod, bracket, or table recommended by the manufacturer or sold with the product. Follow the manufacturer's instructions when installing the product and use mounting accessories recommended by the manufacturer. Only use attachments/accessories specified by the manufacturer

Note: Prolonged use of headphones at a high volume may cause health damage on your ears.

The apparatus should not be exposed to dripping or splashing water; no objects filled with liquids should be placed on the apparatus.

Terminals marked with the "lightning bolt" are hazardous live; the external wiring connected to these terminals require installation by an instructed person or the use of ready made leads or cords.

Ensure that proper ventilation is provided around the appliance. Do not install near any heat sources such as radiators, heat registers, stoves, or other apparatus (including amplifiers) that produce heat.

No naked flame sources, such as lighted candles, should be placed on the apparatus.

Power Cord

Do not defeat the safety purpose of the polarized or grounding-type plug. A polarized plug has two blades with one wider than the other. A grounding type plug has two blades and a third grounding prong. The wide blade or the third prong are provided for your safety. If the provided plug does not fit into your outlet, consult an electrician for replacement of the obsolete outlet. The AC supply cord should be routed so that it is unlikely that it will be damaged. Protect the power cord from being walked on or pinched particularly at plugs. If the AC supply cord is damaged DO NOT OPERATE THE UNIT. To completely disconnect this apparatus from the AC Mains, disconnect the power supply cord plug from the AC receptacle. The mains plug of the power supply cord shall remain readily operable.

Unplug this apparatus during lightning storms or when unused for long periods of time.

Service

The unit should be serviced only by qualified service personnel. Servicing is required when the apparatus has been damaged in any way, such as power-supply cord or plug is damaged, liquid has been spilled or objects have fallen into the apparatus, the apparatus has been exposed to rain or moisture, does not operate normally, or has been dropped.

Veillez Lire le Manuel: Il contient des informations qui devraient être comprises avant l'opération de votre appareil. Conservez. Gardez S.V.P. ces instructions pour consultations ultérieures et observez tous les avertissements.

Nettoyez seulement avec le tissu sec.

Emballage: Conservez la boîte au cas où l'appareil devait être retourner pour réparation.

Avertissement: Pour réduire le risque de feu ou la décharge électrique, n'exposez pas cet appareil à la pluie ou à l'humidité. *N'utilisez pas cet appareil près de l'eau!*

Attention: Lors de l'utilisation de produits électrique, assurez-vous d'adhérer à des précautions de bases incluant celle qui suivent:

Alimentation

L'appareil ne doit être branché qu'à une source d'alimentation correspondant au voltage spécifié dans le manuel ou tel qu'indiqué sur l'appareil. Cet appareil est équipé d'une prise d'alimentation polarisée. Ne pas utiliser cet appareil avec un cordon de raccordement à moins qu'il soit possible d'insérer complètement les trois lames. Des précautions doivent être prises afin d'éviter que le système de mise à la terre de l'appareil ne soit désengagé. Un appareil construit selon les normes de CLASS I devrait être raccordé à une prise murale d'alimentation avec connexion intacte de mise à la masse. Lorsqu'une prise de branchement ou un coupleur d'appareils est utilisée comme dispositif de débranchement, ce dispositif de débranchement devra demeurer pleinement fonctionnel avec raccordement à la masse.

Risque

Ne pas placer cet appareil sur un chariot, un support, un trépied ou une table instables. L'appareil pourrait tomber et blesser quelqu'un ou subir des dommages importants. Utiliser seulement un chariot, un support, un trépied ou une table recommandés par le fabricant ou vendus avec le produit. Suivre les instructions du fabricant pour installer l'appareil et utiliser les accessoires recommandés par le fabricant. Utilisez seulement les attachments/accessoires indiqués par le fabricant

Note: L'utilisation prolongée des écouteurs à un volume élevé peut avoir des conséquences néfastes sur la santé sur vos oreilles. .

Il convient de ne pas placer sur l'appareil de sources de flammes nues, telles que des bougies allumées.

L'appareil ne doit pas être exposé à des égouttements d'eau ou des éclaboussures et qu'aucun objet rempli de liquide tel que des vases ne doit être placé sur l'appareil.

Assurez que l'appareil est fourni de la propre ventilation. Ne procédez pas à l'installation près de source de chaleur tels que radiateurs, registre de chaleur, fours ou autres appareils (incluant les amplificateurs) qui produisent de la chaleur.

Les dispositifs marqués d'une symbole "d'éclair" sont des parties dangereuses au toucher et que les câblages extérieurs connectés à ces dispositifs de connexion extérieure doivent être effectués par un opérateur formé ou en utilisant des cordons déjà préparés.

Cordon d'Alimentation

Ne pas enlever le dispositif de sécurité sur la prise polarisée ou la prise avec tige de mise à la masse du cordon d'alimentation. Une prise polarisée dispose de deux lames dont une plus large que l'autre. Une prise avec tige de mise à la masse dispose de deux lames en plus d'une troisième tige qui connecte à la masse. La lame plus large ou la tige de mise à la masse est prévu pour votre sécurité. La prise murale est désuète si elle n'est pas conçue pour accepter ce type de prise avec dispositif de sécurité. Dans ce cas, contactez un électricien pour faire remplacer la prise murale. Évitez d'endommager le cordon d'alimentation. Protégez le cordon d'alimentation. Assurez-vous qu'on ne marche pas dessus et qu'on ne le pince pas en particulier aux prises. **N'UTILISEZ PAS L'APPAREIL** si le cordon d'alimentation est endommagé. Pour débrancher complètement cet appareil de l'alimentation CA principale, déconnectez le cordon d'alimentation de la prise d'alimentation murale. Le cordon d'alimentation du bloc d'alimentation de l'appareil doit demeurer pleinement fonctionnel.

Débranchez cet appareil durant les orages ou si inutilisé pendant de longues périodes.

Service

Consultez un technicien qualifié pour l'entretien de votre appareil. L'entretien est nécessaire quand l'appareil a été endommagé de quelque façon que se soit. Par exemple si le cordon d'alimentation ou la prise du cordon sont endommagés, si il y a eu du liquide qui a été renversé à l'intérieur ou des objets sont tombés dans l'appareil, si l'appareil a été exposé à la pluie ou à l'humidité, si il ne fonctionne pas normalement, ou a été échappé.

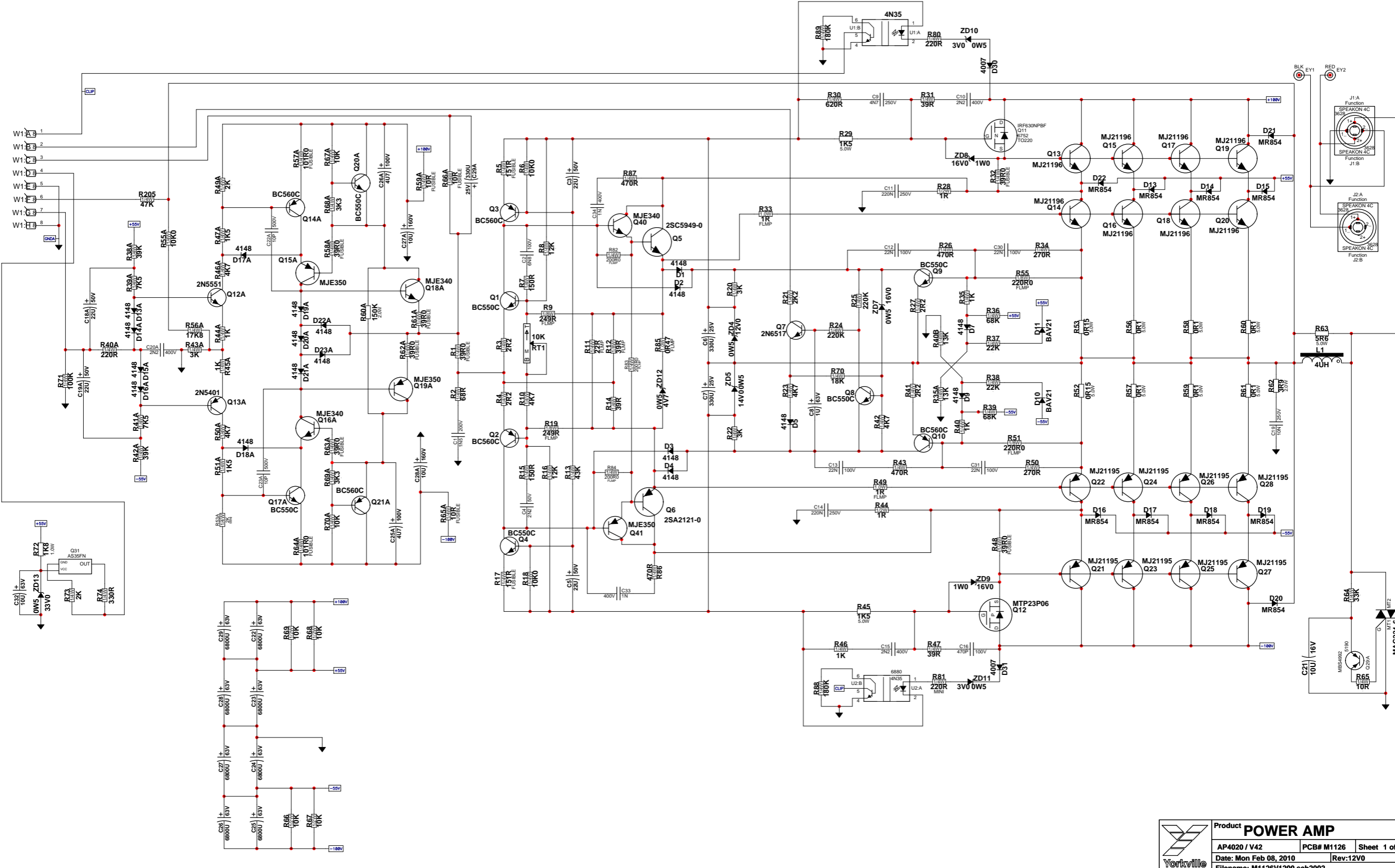

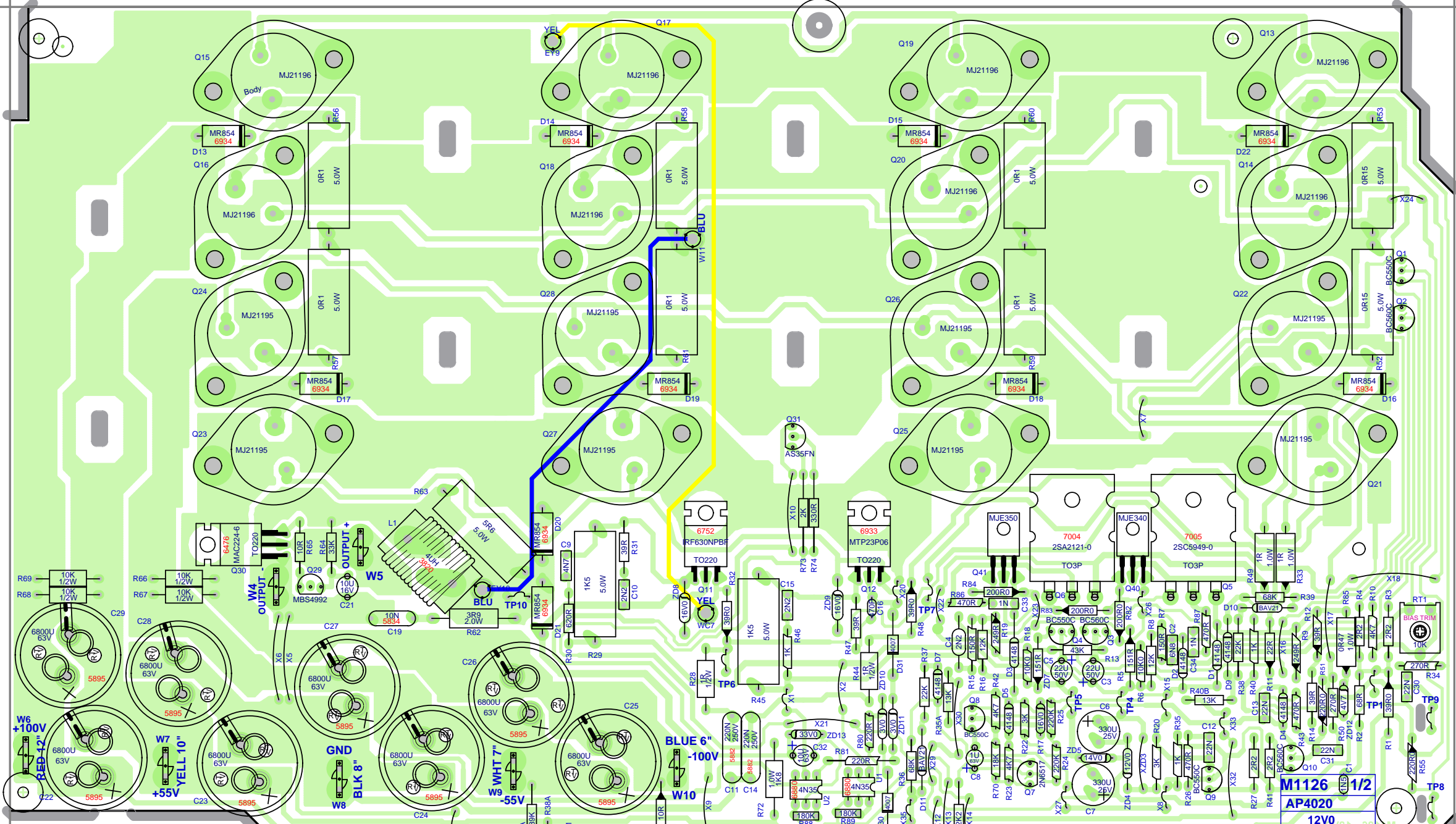

Top Assy M1126 12V0
Pcb Mech M1126 12V0

- SOCKET
- SOCKET UPSIDE DOWN
- NORMAL
- NORMAL LARGE
- SOCKET WITH DIRECTION
- TAB

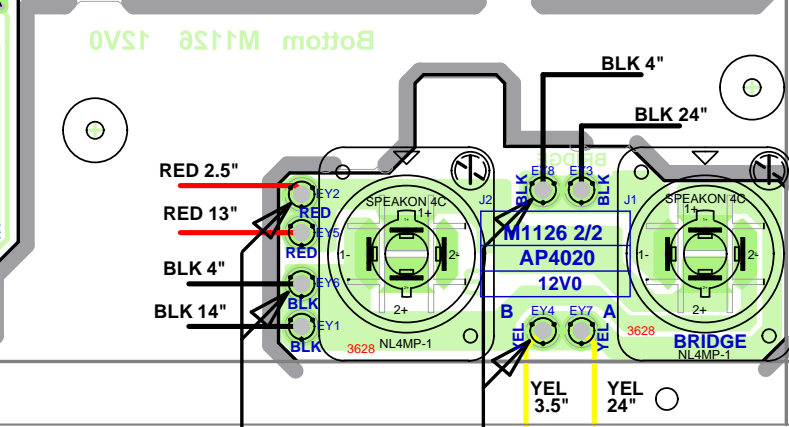

FOR PRODUCT V42 DO NOT STUFF WIRES IN EY2, EY4, EY6, AND EY8.

DO NOT STUFF WIRES OR SPEAKON JACKS FOR SERVICE BOARDS.

SEE LAYOUT DOCUMENTATION





SEE LAYOUT DIAGRAM



M1126 PRODUCTION NOTES

1. MOUNTING DETAILS FOR 5W ADD #8629 SPACERS ONLY ON 5 WATT RESISTORS R29 AND R45. ENSURE SPACERS ARE UNDER RESISTOR BODY ENOUGH TO RAISE IT OFF THE BOARD SURFACE.

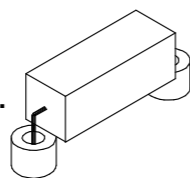

2. MOUNTING HARDWARE FOR Q5 AND Q6.

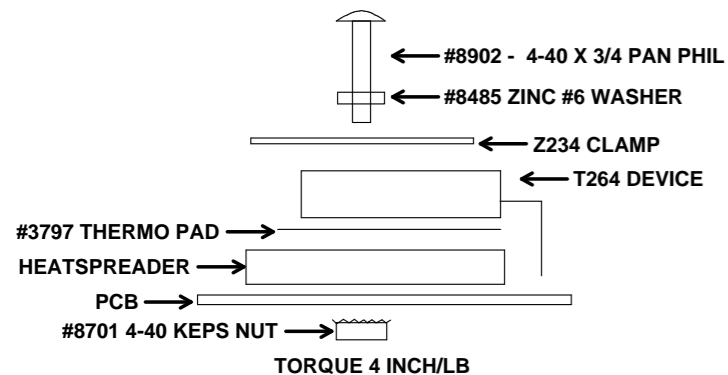

3. MOUNTING HARDWARE FOR Q40 AND Q41.

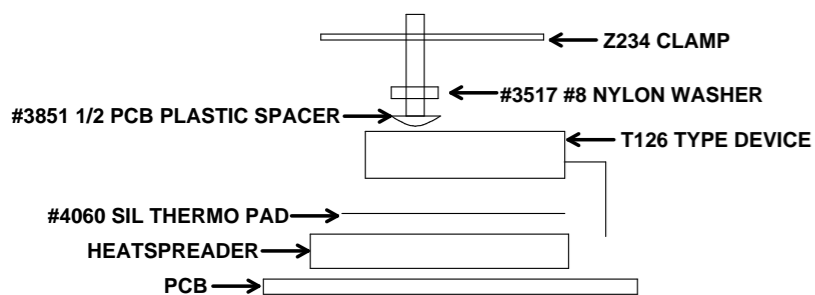

#3851 SPCR Z234 CLAMP #8485 WASHER #8902 440- SCREW

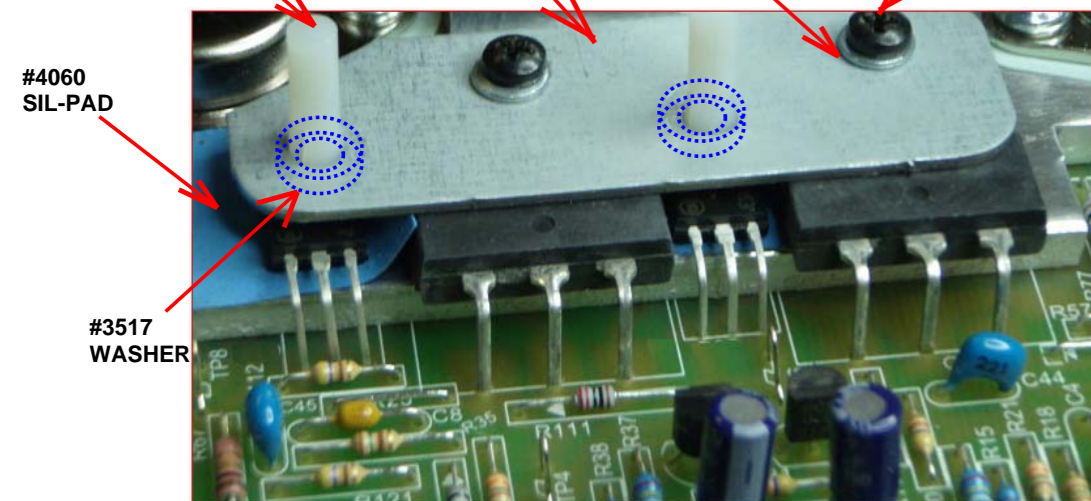

CLAMP DETAIL - SEE NOTES 2 AND 3.

4. MOUNTING HARDWARE FOR Q11,Q12

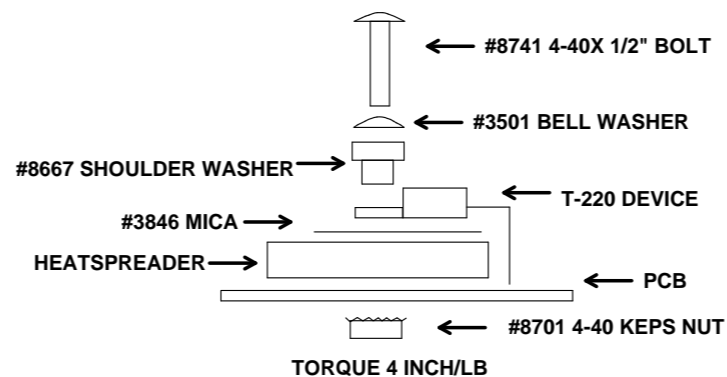

5. MOUNTING HARDWARE FOR TO3 OUTPUTS

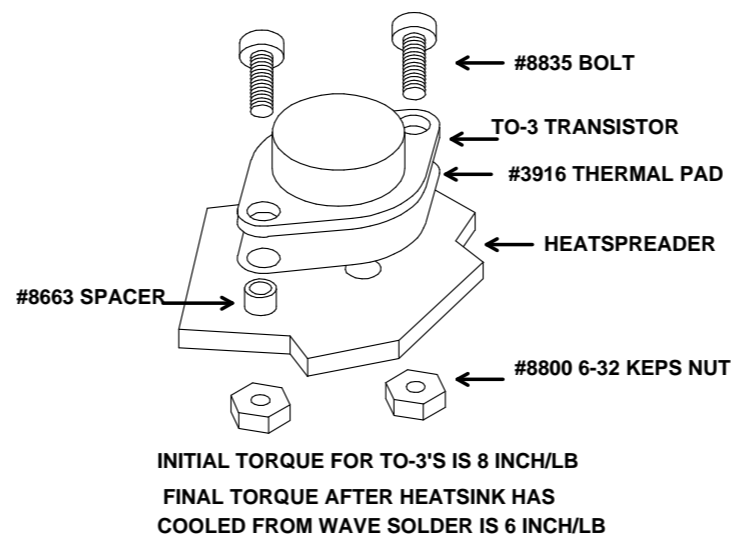

6. USE #2006 SMALL BODY 1R 1W FOR R33 AND R49.

7. MOUNTING DETAILS FOR Q30 TRIAC

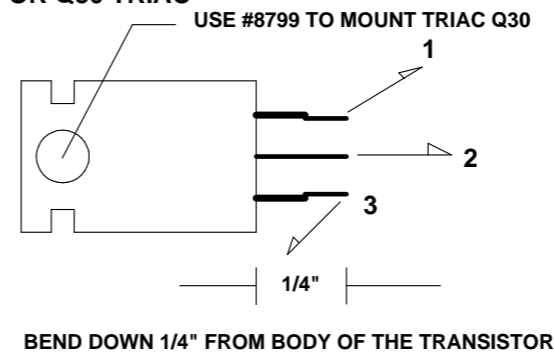

IMPORTANT: AFTER MOUNTING DEVICE DO NOT CUT LEGS BEND LEGS IN DIRECTION SHOWN IT IS IMPRATIVE THAT LEG MARKED 2 AND 3 ARE BENT FLAT AGAINST THE COPPER SURFACE.

8. TAB WIRE COLOURS: W6 RED 16AWG W7 YEL 16AWG W8 BLK 16AWG W9 WHT 16AWG W10 BLU 16AWG W5 OUTPUT + W4 OUTPUT -

9. Q31 IS HAND INSERTED AND BENT OVER WITH FLAT SIDE UP AS SHOWN.

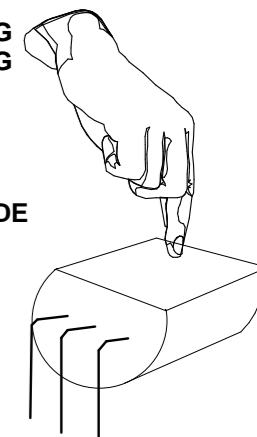

10. DO NOT STUFF WIRES FOR MODEL V42 IN EY1, EY6, EY5, AND EY2. IN AREA INDICATED ON BOARD 2/2



SEE LAYOUT DIAGRAM



M1126 Database History			
MODEL(S):-		AP4020	
#	DATE	VER#	DESCRIPTION OF CHANGE
1	OCT/97	1.00	FIRST PRODUCTION
2	NOV/10/97	1.01	PC#5520 R35A 16K->20K ZD7 20V->16V
3	NOV/19/97	1.10	ROUTING ADDED. HOLE SIZE CHANGES
4	DEC/04/97	1.20	PC#5533 R36,R39 68K->47K. R40B/R35A 20K->16K
5	.	.	R31 47R->39R C10 680p->2n2. C8 2u2->1u
6	JAN/13/98	1.30	PC#5550 R36,R39 68K->47K. R40B,R35A 16K->13K
7	JAN/27/98	2.00	PC#5577 D21 MOVED. X31,X35 ADDED
8	JUN/19/98	2.01	PC#5567 C10,C15,C20A TO PT#5427 2n2
9	OCT/06/98	3.00	TRACE CHANGES TO ELIMINATE SHORTS PC#5729
10	.	.	X5,X6 MOVED
11	JAN/27/99	4.00	PC#5908 U1,U2 4N35->TLP621
12	JUN/11/99	5.00	ONE OF THREE SPEAKON JACKS DELETED
13	JUN/13/99	.	U1,U2 TLP621->4N35. SPKON PCB MOVED FOR SHEAR
1	AUG/12/99	6.00	CORRECT BRIDGED JACK TO A
2	MAY/31/01	7.00	PC#6381 ADD C33/C34,R86/R87 PC#6385 C2,C4 1n->2n2
3	SEP/2004	8.00	PC#6435 C33,C34 220p AXIAL->1n RADIAL. C2 2n2->6n8
4	.	.	PC#6438 ADD R88,R89
5	JAN/24/02	8.10	PC#6506 ZD10,ZD11 4V7->3V0
6	D	8.20	PC#6514 Q13->Q20 #6900->#6909. Q21->Q28 #6927->#6910
7	D	.	R5,R17 249FP->150RFP. R13 22K->43K. ZD5 12V->14V0
8	MAY/16/03	8.30	PC#6607 C10,C15,C20A #5427->#5208 2n2 400V
9	SEP/2004	9.00	REDO SOLDERMASK
10	21/JUN/06	9.10	PC#7083 Q11 MTP10N15SL TO IRF630NPBF
11	17/OCT/06	10.00	CONVERT TO PCAD2002
12	01/NOV/07	11.00	CHANGE CONNECTOR W1 PADS TO OVAL PER PC#7362
13	11/MAR/08	.	PC#7076, REPLACE #6989 & #6990 WITH #7004 & #7005
14	08/FEB/10	12.0	PC#7935 - C25A,C26A CHANGED YS#5259 TO YS#5269 4U7 100V
15	.	.	PC#7916 - ADD PICTURE TO PDF FOR TO3P MTG PLATE
16	.	.	
17	.	.	
18	.	.	

BC550C
BC560C



C B E
TO-92

2N5401
2N5551
MPSA06
MPSA13
MPSA43
MPSA56
MPSA63



TO-92
IN OUT
REF

2N5401
2N5551
MPSA06
MPSA13
MPSA43
MPSA56
MPSA63
MBS4942



MT2
N/C
MT1

2N5401
2N5551
2N6517
MPSA13
MPSA43
MPSA56
MPSA63



E B C
TO-92

IRF830
MTP12P10
MTP10N15L
IRL2910
IRF5210
MTP2P50E
MTP8P20
MTP23P06
IRF822
IRF4905

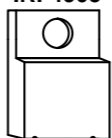

G D S

BD139
BD237
BD238
MJE340
MJE350
MJE271
MJE270
BD140



E C B

BF872
BF871
2N6556
2N6553

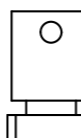

B C E

MAC224

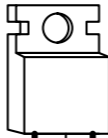

B G
C MT2
E MT1

BD139
BD139
BD139

MJL21194
MJL1302A
MJL3281A
MJL21193
2SA2121-0
2SC5949-0

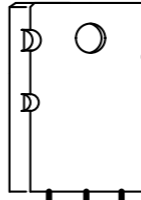

B C E

MJE11025

MJE11025

MJ21195

MJ21196

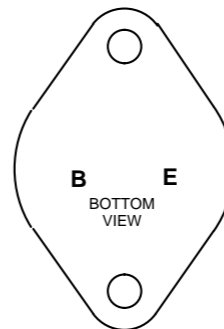

Mnnnn Drilling History			
MODEL(S):-		{MODEL}	
#	DATE	VER#	DESCRIPTION OF CHANGE
1	D	V	N
2	D	V	N
3	D	V	N
4	D	V	N
5	D	V	N
6	D	V	N
7	D	V	N
8	D	V	N
9	D	V	N
10	D	V	N
11	D	V	N
12	D	V	N
13	D	V	N

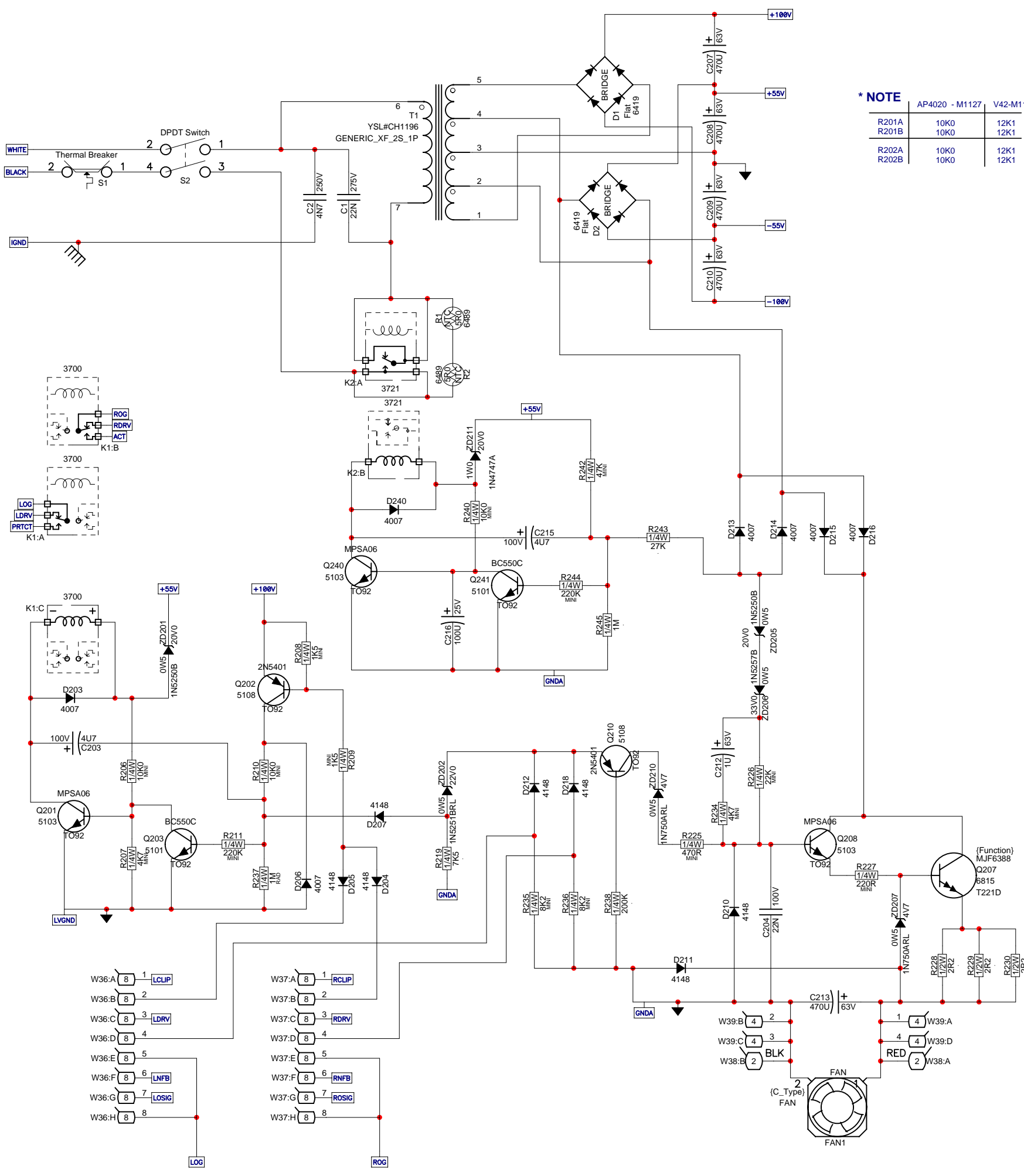

*** NOTE**

R201A	10K0	12K1
R201B	10K0	12K1
R202A	10K0	12K1
R202B	10K0	12K1

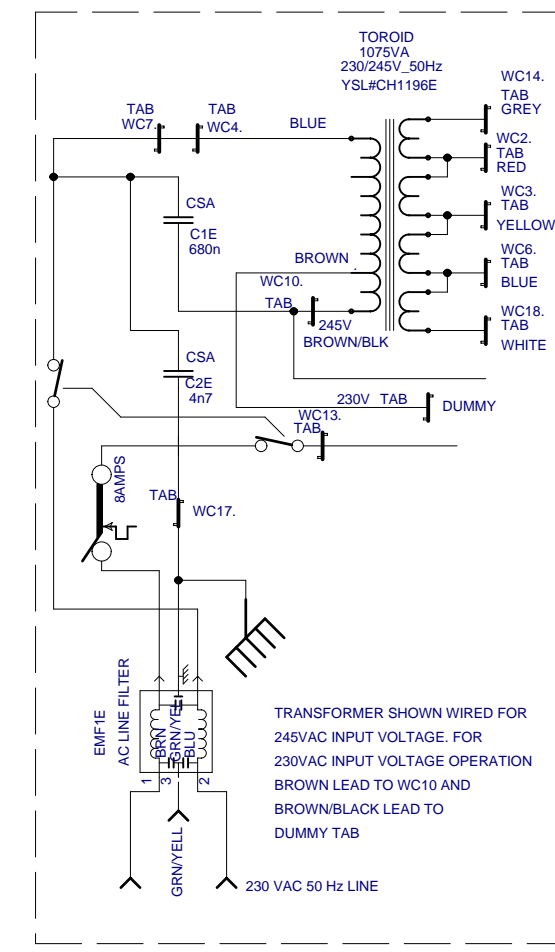
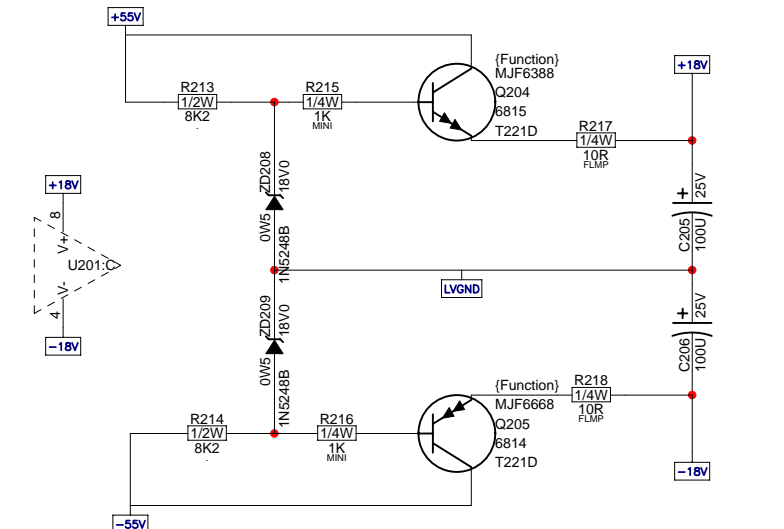
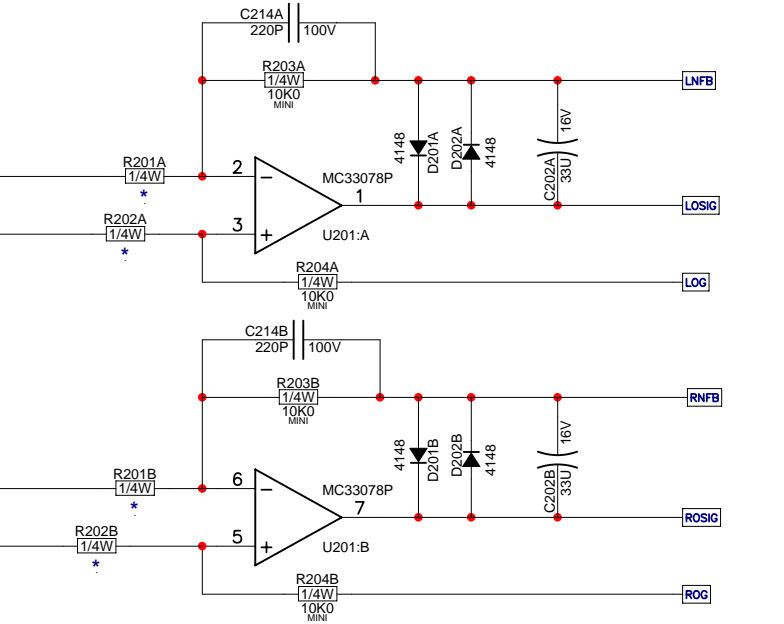
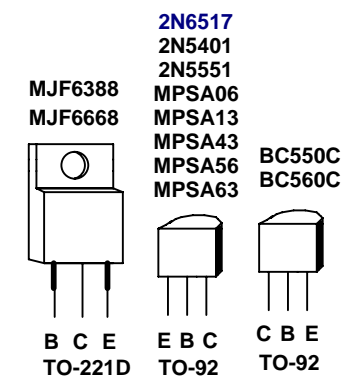
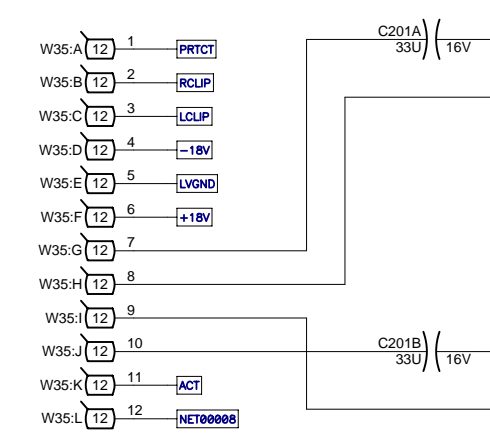

X8013 Database History		
MODEL(S):-	AP4020 / V42	
#	DATE	VER# DESCRIPTION OF CHANGE
1	OCT/97	1.00 FIRST PRODUCTION
2		R232 150R->270R R233 270R ->470R
3	NOV/13/97	1.01 PC#5514 R232 270R->470R
4	NOV/25/97	2.00 PC#5532 DELETE TRIAC ADD RELAY. R233 2R0->10R ZD208,ZD209 20V->18V. U201 TL072->33078
5		
6	DEC/12/97	3.00 UPDATE FOR AP4040
7	JAN/21/98	4.00 PC#5578 CORRECT SPACING FOR R228,R229, R230
8		PC#5579 REDO AC FOR 4N7. ADD DUMMY TABS FOR Q204
9	MAR/27/98	5.00 PC#5649 ADD SURGISTORS. DELETE R233
10	JUL/15/98	5.10 PC#5797 R235/236 10K->8K2, ZD202 27V->22V
11		ZD210 6V2->4V7, ZD212 REPLACED BY JUMPER
12	OCT/27/99	6.00 PC#5695 ADD TP9, TP10 ENLARGE SOME TRACES
13	APR/06/00	7.00 PC#6218 PADS AND HOLES FOR RELAY UPDATED
1	DEC/19/01	8.00 BRIDGE MOUNTING CHANGED
2	JAN/15/02	9.00 NEW SOLDERMASK FOR TABS
3	FEB/13/03	10.00 MOVE TRACES AWAY FROM WC6 (POTENTIAL SHORT)
4	MAY/10/05	11.00 REDO SOLDERMASK FOR 0.030
5	SEP/2005	12.00 CONVERT TO PCAD2002
6	03-JUN-2009	13.00 CREATE X8013, M1127 FOR AP4020 AND M1138 FOR V42
7		
8		
9		
10	03-FEB-2010	PC#7718, ONLY FOR V42. CHANGE R201A,R201B,R202A,R202B FROM 10K0 TO #4773 12K1 1% 1/4W
11		PER PCs 7718 and 7738
12		PC#7935: Change C203, C215 from #5259 to #5269
13		

Yorkville

Product **AP4020 / V42**

Sheet1 PCB# Sheet 1 of 1

Date: Wed Feb 03, 2010 Rev:13V00 YsType:..

Filename: X8013V1300sch.sch2002

BlankSize - 14000x8000

M1138 V42

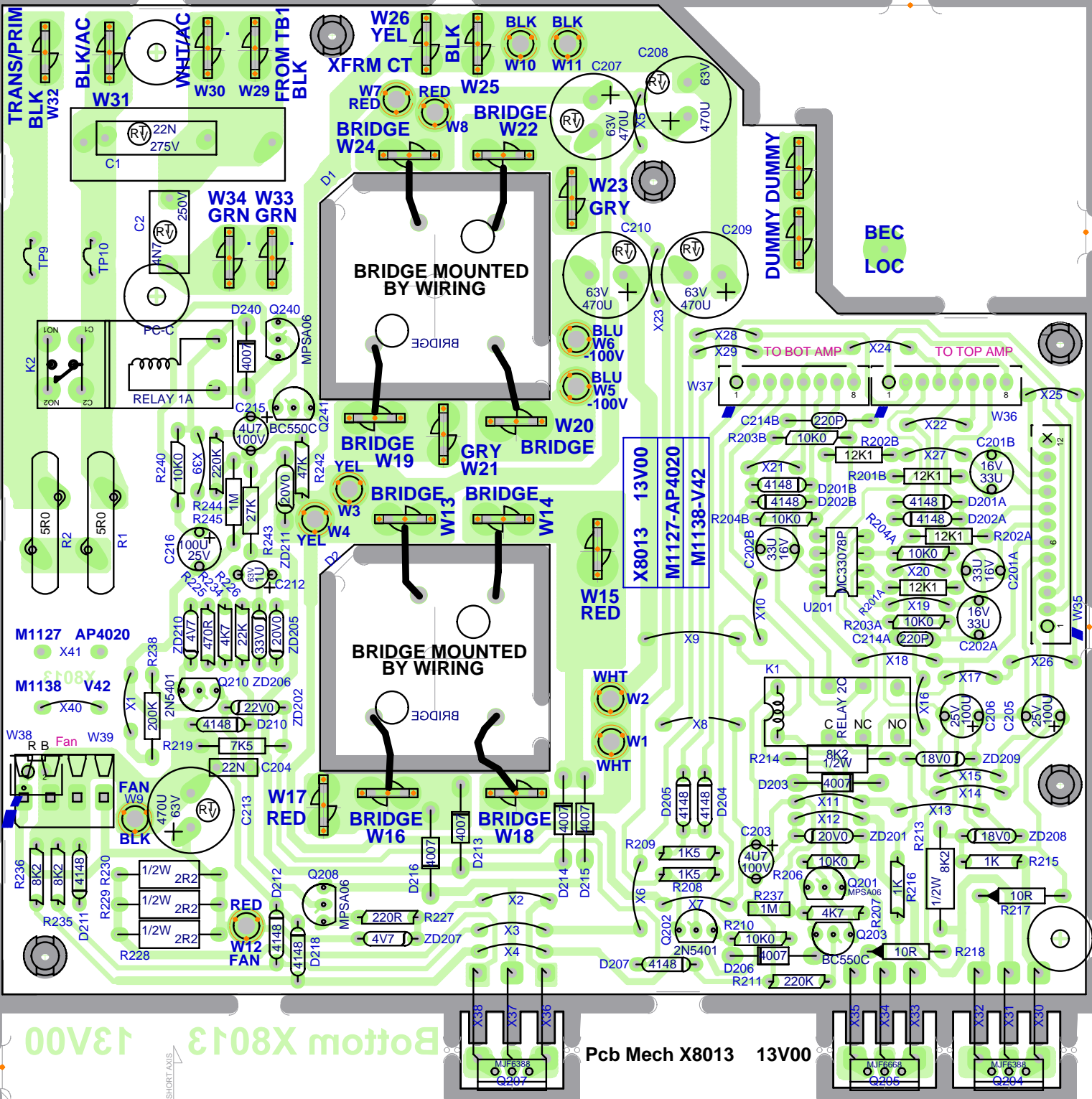

BELOC

BRIDGE MOUNTED BY WIRING

BRIDGE MOUNTED BY WIRING

X8013 13V00
 M1127-AP4020
 M1138-V42

Pcb Mech X8013 13V00

Top Assy X8013 13V00

Bottom X8013 13V00

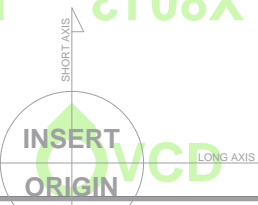

SEE LAYOUT DOCUMENTATION





SEE LAYOUT DIAGRAM



PRODUCTION NOTES:

M1138 V42

1 FOR C1 USE 22N FOR NORTH AMERICAN AND 680N FOR EURO.

2 ADD RTV UNDER RELAY AND BEND LEADS FLAT TO PCB.





SEE LAYOUT DIAGRAM



X8013 Database History			
MODEL(S):-		AP4020 / V42	
#	DATE	VER#	DESCRIPTION OF CHANGE
1	OCT/97	1.00	FIRST PRODUCTION
2	.	.	R232 150R->270R R233 270R ->470R
3	NOV/13/97	1.01	PC#5514 R232 270R->470R.
4	NOV/25/97	2.00	PC#5532 DELETE TRIAC ADD RELAY. R233 2R0->10R
5	.	.	ZD208,ZD209 20V->18V. U201 TL072->33078
6	DEC/12/97	3.00	UPDATE FOR AP4040
7	JAN/21/98	4.00	PC#5578 CORRECT SPACING FOR R228,R229, R230
8	.	.	PC#5579 REDO AC FOR 4N7. ADD DUMMY TABS FOR CE
9	MAR/27/98	5.00	PC#5649 ADD SURGISTORS. DELETE R233
10	JUL/15/98	5.10	PC#5797 R235/236 10K->8K2, ZD202 27V->22V
11	.	.	ZD210 6V2->4V7. ZD212 REPLACED BY JUMPER
12	OCT/27/99	6.00	PC#5695 ADD TP9, TP10 ENLARGE SOME TRACES
13	APR/06/00	7.00	PC#6218 PADS AND HOLES FOR RELAY UPDATED
1	DEC/19/01	8.00	BRIDGE MOUNTING CHANGED
2	JAN/15/02	9.00	NEW SOLDERMASK FOR TABS
3	FEB/13/03	10.00	MOVE TRACES AWAY FROM WC6 (POTENTIAL SHORT)
4	MAY/10/05	11.00	REDO SOLDERMASK FOR 0.030" SPREAD
5	SEP/2005	12.00	CONVERT TO PCAD2002
6	03-JUN-2009	13.00	CREATE X8013, M1127 FOR AP4020 AND M1138 FOR V42
7	.	.	PC#7718, ONLY FOR V42. CHANGE R201A,R201B,R202A
8	.	.	R202B FROM 10K0 TO #4773 12K1 1% 1/4W
9	.	.	PER PCs 7718 and 7738
10	03-FEB-2010	.	PC7935: Change C203, C215 from #5259 to #5269
11	D	V	N
12	D	V	N
13	D	V	N

PIN CONFIGURATION

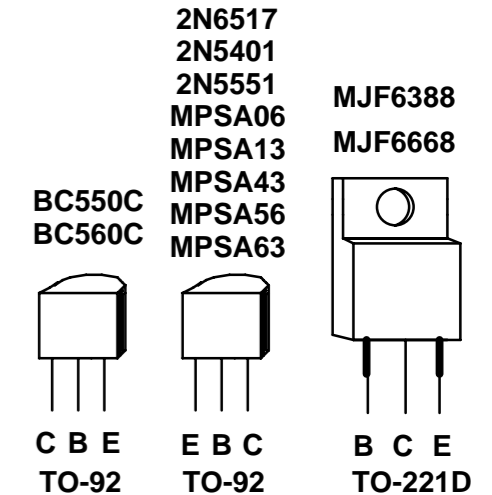

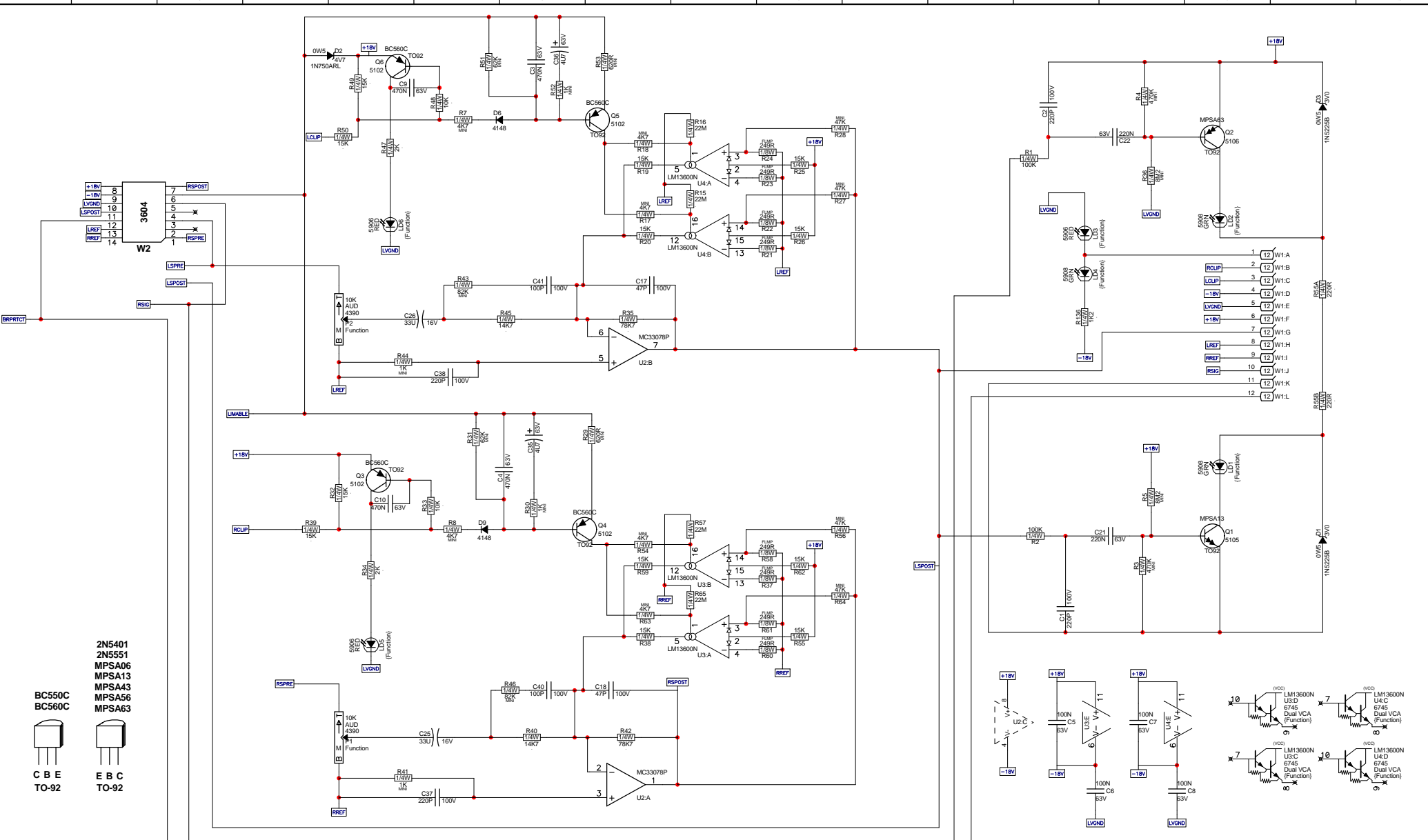

2N5401
2N5551
MPSA06
MPSA13
MPSA43
MPSA56
MPSA63

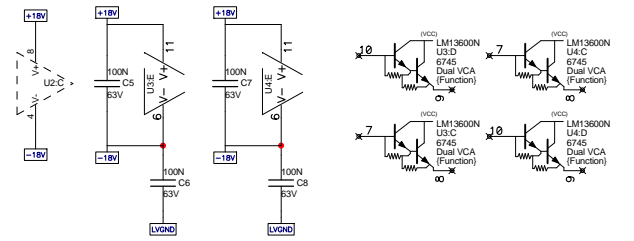
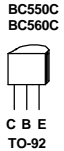

X8011 PCB_DATABASE_HISTORY			
MODEL(S):- AP4020 AND AP4040/VX2400 AND VX2402/V42 AND V44			
#	DATE	VER#	DESCRIPTION OF CHANGE
1	OCT/97	1.00	FIRST PRODUCTION
2	APR/17/98	2.00	#5664 RIBBON CABLE CONNECTIONS CHANGED FOR PROTECT CIRCUIT
3	.	.	.
4	DEC/09/98	3.00	PC#5736 TRACES CHANGED POT SUPPORT SCREWS ADDED
5	.	.	.
6	NOV/20/01	3.10	PC#6466 LD7,LD8 NSL28AA->NSL32SR2
7	JUL/09/02	4.00	PC#6401 PARTS MOVED NEAR P2
8	OCT/25/02	4.10	PC#6568 R44/R41 10K->1K
9	APR/15/05	5.00	PC#6873 REDO SOLDERMASK
10	JUN/05/06	6.00	PC#7138:GT:CONVERT TO PCAD2002. CHANGE OPTO LIMITER TO 13600 #6745 LIMITERS FOR ROHS
11	.	.	REPLACE C3,C4,C9 AND C10 WITH #5234 470N 63V
12	.	.	REPLACE R31 AND R51 WITH #6139 62K 1/4W
13	.	.	.

1	.	.	REPLACE R4 WITH #6127 470K 1/4W
2	JUN/23/08	7.00	Removed shear, solder update, std board size
3	03-MAR-2009	8.00	CREATE X8011, M1128 FOR AP, VX AND M1133 FOR VTC
4	.	.	PC#7717, M1133,V42 AND V44 CHNAGE R34 AND R47 FROM 470R TO 2K #4808
5	.	.	.
6	D	V	N
7	D	V	N
8	D	V	N
9	D	V	N
10	D	V	N
11	D	V	N
12	D	V	N
13	D	V	N

X8011 DRILL HISTORY			
MODEL(S):- AP4020 AND AP4040/VX2400 AND VX2402/V42 AND V44			
#	DATE	VER#	DESCRIPTION OF CHANGE
1	D	V	N
2	D	V	N
3	D	V	N
4	D	V	N
5	D	V	N
6	D	V	N

X8011 PENDING CHANGES		
MODEL(S):- AP4020 AND AP4040/VX2400 AND VX2402/V42 AND V44		
#	PC#	PENDING CHANGE
1	PC	X
2	PC	X
3	PC	X
4	PC	X
5	PC	X
6	PC	X

*PLACE IMPLEMENTED CHANGES INTO BOARD HISTORY



Product **AP-VX-VTC POT PCB**

POT PCB

PCB# X8011

Sheet 2 of 2

Date: Tue Mar 03, 2009

Rev: 8V00

Filename: X8011V800sch.sch2002

M1133 V42/V44

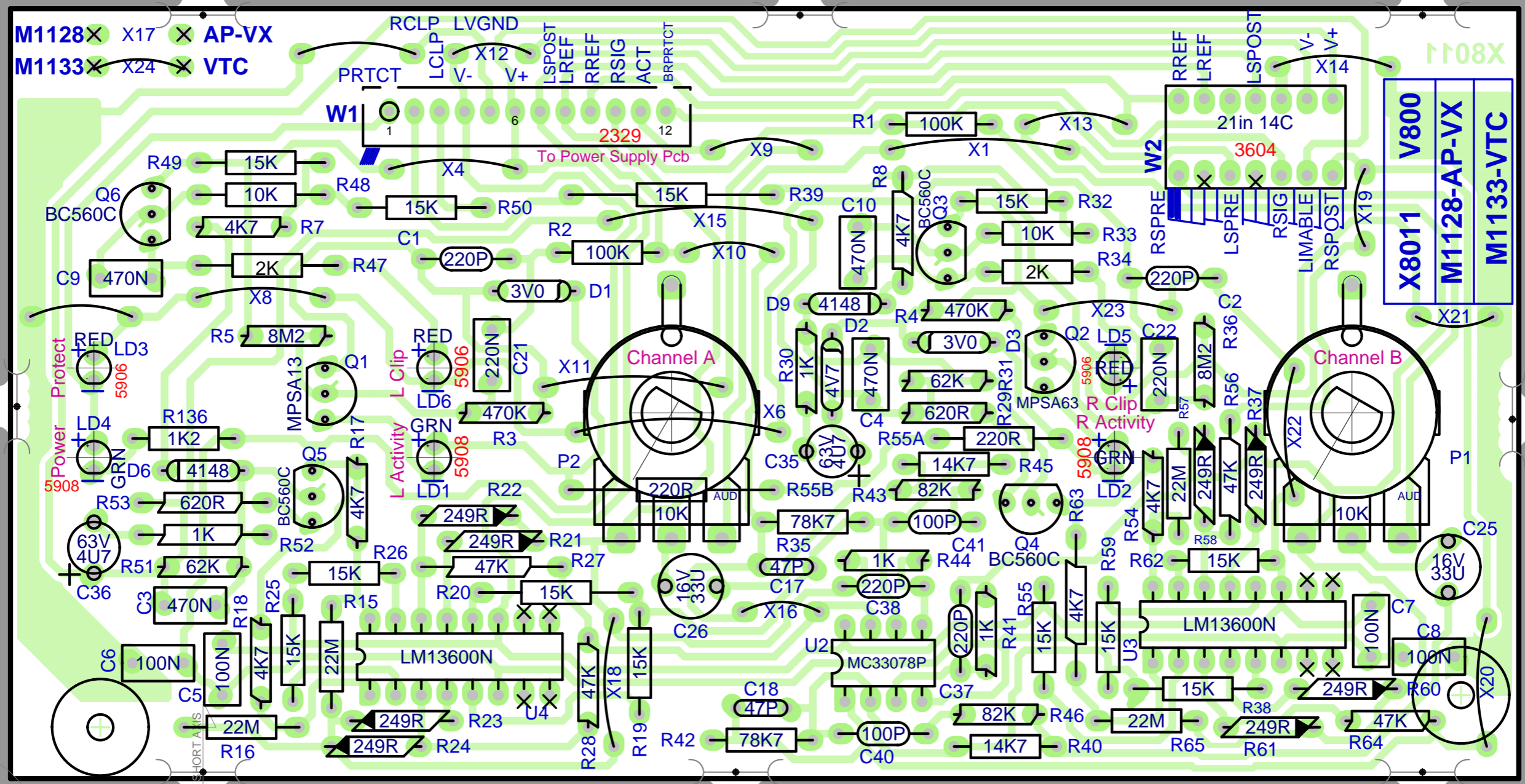

BlankSize - 14000x11000

StepAndRepeat - X2@6.875 Y3@3.300

SEE LAYOUT DOCUMENTATION





SEE LAYOUT DIAGRAM



X8011 PRODUCTION NOTES - M1133 V42/V44

1.

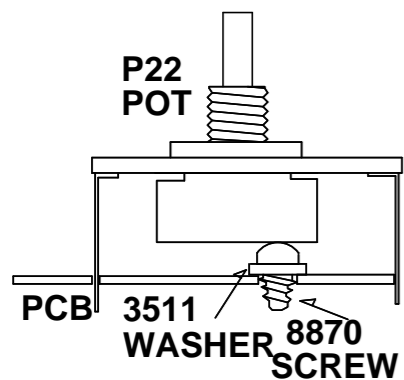

2.

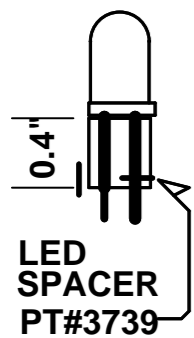



SEE LAYOUT DIAGRAM



X8011 PCB_DATABASE_HISTORY			
MODEL(S):- AP4020 AND AP4040/VX2400 AND VX2402/V42 AND V44			
#	DATE	VER#	DESCRIPTION OF CHANGE
1	OCT/97	1.00	FIRST PRODUCTION
2	APR/17/98	2.00	#5664 RIBBON CABLE CONNECTIONS CHANGED FOR PROTECT CIRCUIT
3	.	.	.
4	DEC/09/98	3.00	PC#5736 TRACES CHANGED POT SUPPORT SCREWS ADDED
5	.	.	.
6	NOV/20/01	3.10	PC#6466 LD7,LD8 NSL28AA->NSL32SR2
7	JUL/09/02	4.00	PC#6401 PARTS MOVED NEAR P2
8	OCT/25/02	4.10	PC#6568 R44/R41 10K->1K
9	APR/15/05	5.00	PC#6873 REDO SOLDERMASK
10	JUN/05/06	6.00	PC#7138:GT:CONVERT TO PCAD2002. CHANGE OPTO LIMITER TO 13600 #6745 LIMITERS FOR ROHS
11	.	.	REPLACE C3,C4,C9 AND C10 WITH #5234 470N 63V
12	.	.	REPLACE R31 AND R51 WITH #6139 62K 1/4W
13	.	.	.
1	.	.	REPLACE R4 WITH #6127 470K 1/4W
2	JUN/23/08	7.00	Removed shear, solder update, std board size
3	28-MAY-2009	8.00	CREATE X8011, M1128 FOR AP, VX AND M1133 FOR VTC
4	.	.	PC#7717, 7718 - M1133,V42 AND V44 CHANGE R34 AND R47 FROM 470R TO 2K #4808
5	.	.	.
6	D	V	N
7	D	V	N
8	D	V	N
9	D	V	N
10	D	V	N
11	D	V	N
12	D	V	N
13	D	V	N

X8011 DRILL HISTORY			
MODEL(S):- AP4020 AND AP4040/VX2400 AND VX2402/V42 AND V44			
#	DATE	VER#	DESCRIPTION OF CHANGE
1	D	V	N
2	D	V	N
3	D	V	N
4	D	V	N
5	D	V	N
6	D	V	N

X8011 PENDING CHANGES			
MODEL(S):- AP4020 AND AP4040/VX2400 AND VX2402/V42 AND V44			
#	PC#	PENDING CHANGE	
1	PC	X	
2	PC	X	
3	PC	X	
4	PC	X	
5	PC	X	
6	PC	X	

*PLACE IMPLEMENTED CHANGES INTO BOARD HISTORY

LEAD/PIN REFERENCE

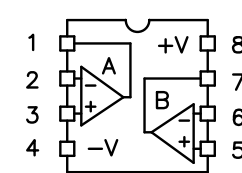
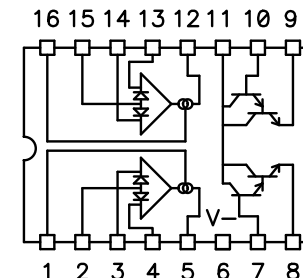

BC550C
BC560C



C B E
TO-92

2N5401
2N5551
MPSA06
MPSA13
MPSA43
MPSA56
MPSA63



E B C
TO-92

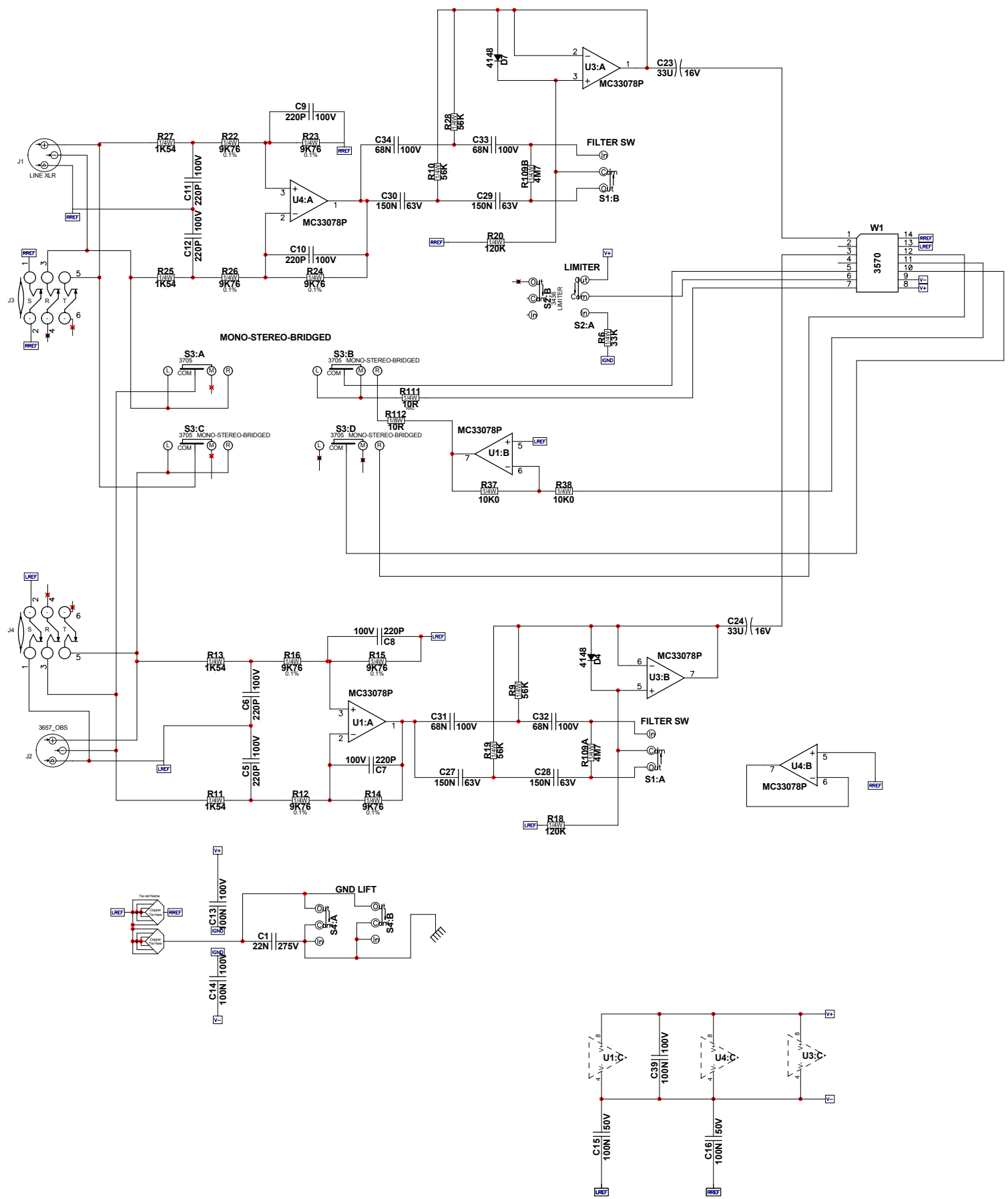

M1129 Database History		
MODEL(S):- AP2020 AP4020 AP4040 AM1CE		
#	DATE	VER# DESCRIPTION OF CHANGE
1	OCT/97	1.00 FIRST PRODUCTION
2	NOV/97	2.00 SWITCH NETS RREF WITH LREF AND RSPRE WITH LSPRE AT 14 PIN CONNECTOR. INPUT TO NONINVERTING
3		
4	DEC/02/97	3.00 CHANGE C27, C29, C28, C30 TO 150N
5	APR/16/98	4.00 PC#5694 PINS 10-12 OF MC2 CONNECTED TO BRG SWT
6	JUL/01/98	4.00 ISOLATE PIN OF S3
7	SEP/06/01	4.10 PC#6364 REPLACE R119 (10K) WITH JUMPER X119
8	APR/15/05	5.00 PC#6873 REDO SOLDERMASK
9	JUL/2005	6.00 CONVERT TO PCAD2002, PC#6944:ROUTE GAUGE, PC#6914:ADD TARGETS
10	AUG-15-2005	
11	D	V N
12	D	V N
13	D	V N

M1129.sch_schematic-DATABASE_HISTORY		
MODEL(S):- AP4020 / AP4040 / AP2020 / AM1CE		
#	DATE	VER# DESCRIPTION OF CHANGE
1	OCT/1997	1.00 FIRST PRODUCTION
2	NOV/12/97	2.00 REVERSED INPUT POLARITY. MODIFIED FOR AP2020
3	DEC/02/97	3.00 C27, C28, C29, C30 TO 150n
4	APR/2/98	2.10 PC#6364 ADD NETS BRPRTCT, LVGND-28 TO BRG SW
5	SEP/06/01	2.20 DELETE R119
6	JUL/2005	3.00 CONVERT TO PCAD2002
7	D	V N
8	D	V N
9	D	V N
10	D	V N
11	D	V N
12	D	V N
13	D	V N

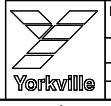
Product {Drawing Number}
(Title) PCB# M1129 Sheet 1 of 2
Date: Tue May 02, 2006 **Rev:** v6.00
Filename: M1129-6v00.sch2002

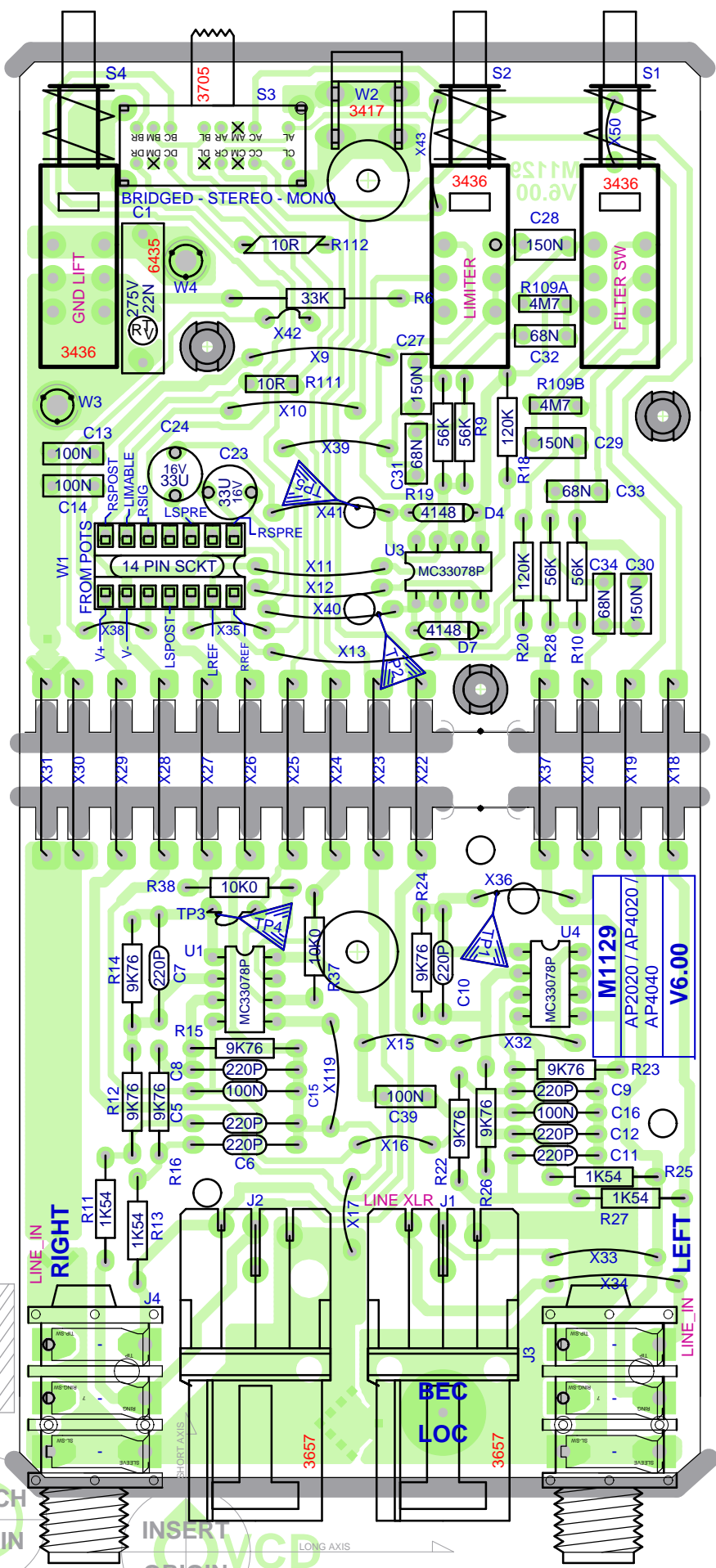
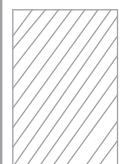

BRIDGED - STEREO - MONO

GND LIFT
3436

LIMITER
3436

FILTER SW
3436

FROM POTS
14 PIN SCKT

M1129
AP2020 / AP4020 /
AP4040
V6.00

LINE_IN
RIGHT

LINE_XLR J1

LINE_IN
LEFT

BEC
LOC

INSERT ORIGIN
LONG AXIS

M1129.sch_schematic-DATABASE_HISTORY

MODEL(S):- AP4020 / AP4040 / AP2020 / AM1CE			
#	DATE	VER#	DESCRIPTION OF CHANGE
1	OCT/1997	1.00	FIRST PRODUCTION
2	NOV/12/97	2.00	REVERSED INPUT POLARITY. MODIFIED FOR AP2020
3	DEC/02/97	.	C27, C28, C29, C30 TO 150n
4	APR/22/98	2.10	PC#5694 ADD NETS BRPRTCT, LVGND-28 TO BRG SW
5	SEP/06/01	2.20	DELETE R119
6	JUL/2005	3.00	CONVERT TO PCAD2002
7	D	V	N
8	D	V	N
9	D	V	N
10	D	V	N
11	D	V	N
12	D	V	N
13	D	V	N

M1129 DRILL HISTORY

MODEL(S):- AP2020/AP4020/AP4040/AM1CE			
#	DATE	VER#	DESCRIPTION OF CHANGE
1	APR-03-2003	V06	N
2	AUG-15-2005	V07	CONVERT TO PCAD2002
3	D	V	N
4	D	V	N
5	D	V	N
6	D	V	N

M1129 Database History

MODEL(S):- AP2020 AP4020 AP4040 AM1CE			
#	DATE	VER#	DESCRIPTION OF CHANGE
1	OCT/97	1.00	FIRST PRODUCTION
2	NOV/97	2.00	SWITCH NETS RREF WITH LREF AND RSPRE WITH
3	.	.	LSPRE AT 14 PIN CONNECTOR. INPUT TO NONINVERTING
4	DEC/02/97	.	CHANGE C27, C29, C28, C30 TO 150N
5	APR/16/98	3.00	PC#5694 PINS 10-12 OF MC2 CONNECTED TO BRG SWT
6	JUL/01/98	4.00	ISOLATE PIN OF S3
7	SEP/06/01	4.10	PC#6436 REPLACE R119 (10K0) WITH JUMPER X119
8	APR/15/05	5.00	PC#6873 REDO SOLDERMASK
9	JUL/2005	6.00	CONVERT TO PCAD2002, PC#6944:ROUTE GAUGE,
10	AUG-15-2005	.	PC#6914:ADD TARGETS
11	D	V	N
12	D	V	N
13	D	V	N

M1129 PRODUCTION NOTES

- 1 FOR XLR #3657 USE SCREW PT#8829
UP THROUGH THE BOTTOM
- 2 FOR M1129B VX1200/2400/J/2402
DO NOT STUFF X40 AND X41
ADD WIRES IN BOARD ASSEMBLY

M1129 PENDING CHANGES

MODEL(S):- AP2020/AP4020/AP4040/AM1CE		
#	PC#	PENDING CHANGE
1	PC	X
2	PC	X
3	PC	X
4	PC	X
5	PC	X
6	PC	X

***PLACE IMPLEMENTED CHANGES INTO BOARD HISTORY**